

SUS304 Platform

SUS304 stainless steel material
Low profile with detachable ramp
3 different platform size for selection
- customized platform available
Polishing finish

M28s | B8D LoadCell

Standard s.s M28s load cell - Models1
OIML/NTEP s.s B8D load cell - Models2

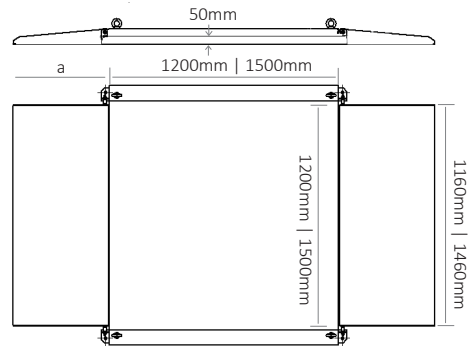

a = default of 300mm ramp, optional 500mm

Optional K7s Indicator

Big backlit FSTN LCD display, the weight can be read clearly even in the sun. SUS304 s.s IP66 housing, suitable for harsh environment, with rechargeable battery, 100-240v power source directly, kg/lb unit exchange, animal weighing function, accumulating, hold, x10 accuracy, counting, zero, tare, printing, etc. Default with 2 RS232 connector, options of Bluetooth or WiFi.



Indicator X3WGM optional
OIML/EC Type approved.

Rechargeable battery, Programming zero tracking, Kg/lb units, counting function, animal weighing, Hold function, accumulation, RS232 interface



Accessories

ISB | ISC | MDSS | RFS

Models * Prices not include indicators

Part No.	100433	100434	100435	100436
Models1	FTLS1210	FTLS1220	FTLS1510	FTLS1520
U.P.(USD)	\$3,560.00	\$3,560.00	\$4,600.00	\$4,600.00
Part No.	100437	100438	100439	100440
Models2	FTLS1210M	FTLS1220M	FTLS1510M	FTLS1520M
U.P.(USD)	\$4,120.00	\$4,120.00	\$5,160.00	\$5,160.00
Capacity	1000kg	2000kg	1000kg	2000kg
Division	0.2 0.5kg	0.5 1kg	0.2 0.5kg	0.5 1kg
Size	1200 x 1200mm		1500 x 1500mm	
Weight	180kg		230kg	

Platform Sizes

1200 x 1200mm
1500 x 1500mm

Capacity

1000kg | 2000kg

Division

0.2kg | 0.5kg | 1.0kg

Load Cell Approval

M28s - CE
B8D - OIML/NTEP

Load Cell Protection

IP67

Operating Temperature

-10 - 40°C

Power

100-240V AC/DC adaptor
Battery: 6V1.2Ah - K7s
Battery: 6V2.8Ah - X3WGM

Indicator & Protection

K7s - CE - IP66
X3WGM - OIML/EC Type - IP66

Display

37mm FSTN LCD - K7s
20mm green LED - X3GM

Unit

Kg | lb, g | oz, t - K7s
Kg | lb - X3GM

Output

RS232 * 2 - K7s
RS232 - X3GM

Value Each Gram A professional weighing products manufacturer and supplier