

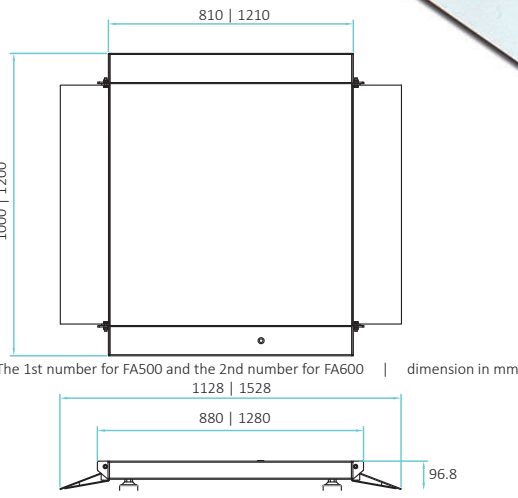

MDS

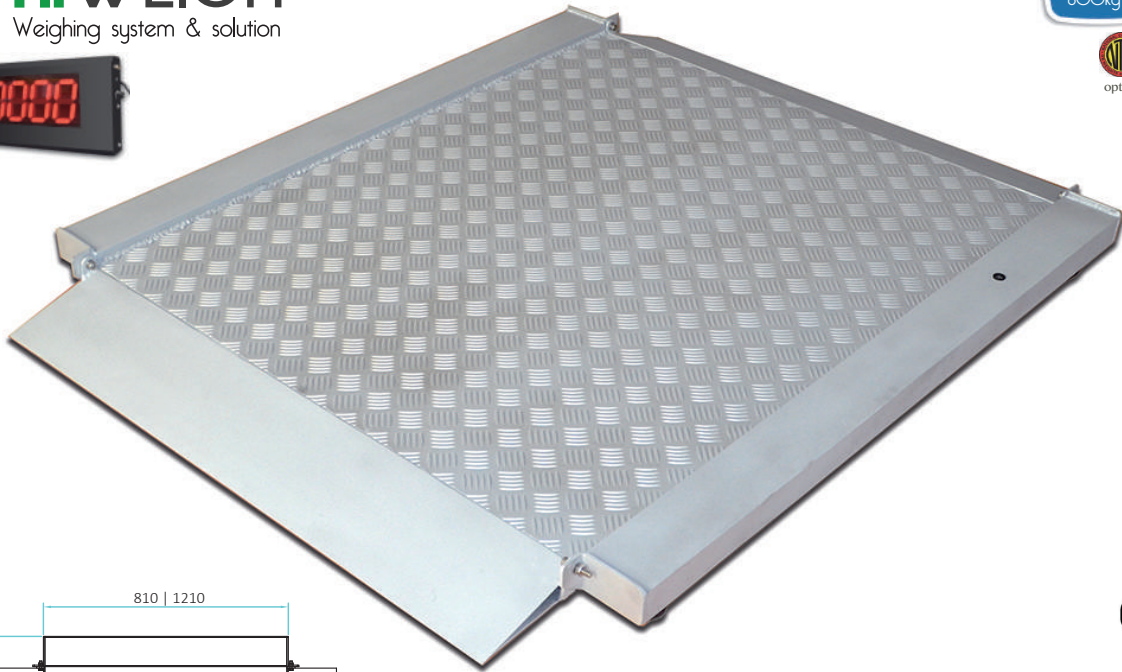

Low Profile
Aluminum Platform
Low profile design
Aluminum alloy material
Checked plate or smooth plate
Foldable ramp for each size



H8C | M28 LoadCell
IP67 protection, with alloy steel feet
FAM* with standard M28 load cells
FAM*M with OIML/NTEP approved H8C load cells

Platform Sizes
800*800mm
1000*1200mm
** customized size available*

Capacity
500kg | 600kg

Display Resolution
1/3,000

Load Cell Approval
M28 - CE
H8C - OIML | NTEP
Protection - IP67

Operating Temperature
-10 - 40°C

Optional Indicator
X3AC | X3AM

Power
100-240V - 12V adaptor
Battery: 6V2.8Ah - 24hrs
Charging time: 8 hrs

Display
X3AC - 1" FSTN LCD
X3AM - 1" LCD

Indicator Approval
X3AC - CE
X3AM - OIML/EC Type

Unit
Kg | lb

Output
RS232
** optional Bluetooth, WiFi, USB*

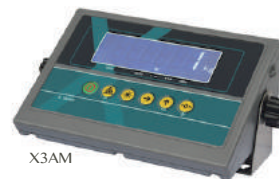

Optional Indicator
ABS housing with s.s bracket
X3AC - models 1 (CE)
X3AM - models 2 (CE | OIML)
Rechargeable battery
Programming zero tracking
Selectable Kg/lb units
Counting function
Animal weighing
Hold function
Power saving mode
Accumulation
RS232 interface

Accessories
RAMP | ISA | MDS | PITF

Models * Prices not include indicators

Part No.	100465	100466	100467	100468
Models	FAM500	FAM500M	FAM600	FAM600M
U.P.(USD)	\$1,920.00	\$2,040.00	\$2,480.00	\$2,600.00
Capacity	500kg		600kg	
Division	0.2kg		0.2kg	
Size	800 x 800mm		1000 x 1200mm	
Weight	35kg		65kg	